

National Concrete Pavement Technology Center



Impact of deicing chemicals, construction vehicle loads and freeze-thaw cycles on deterioration of concrete joints

Maxim M. Prokudin, MS, EIT
Peter C. Taylor, PhD, PE (IL)



Tasks Undertaken

- Does salting increase or decrease the number of freeze thaw cycles?
- Construction traffic loading?
- Can we reproduce this in the lab?

Number of Cycles?

Does salting increase or decrease the number of freeze thaw cycles?

- Salt does not change the temperature
- Salt does change the freezing point
- Some salts are hydrophilic
- Data based on air temperature – pavement is likely warmer

Freeze - thaw cycles

Des Moines, IA 2005-2006

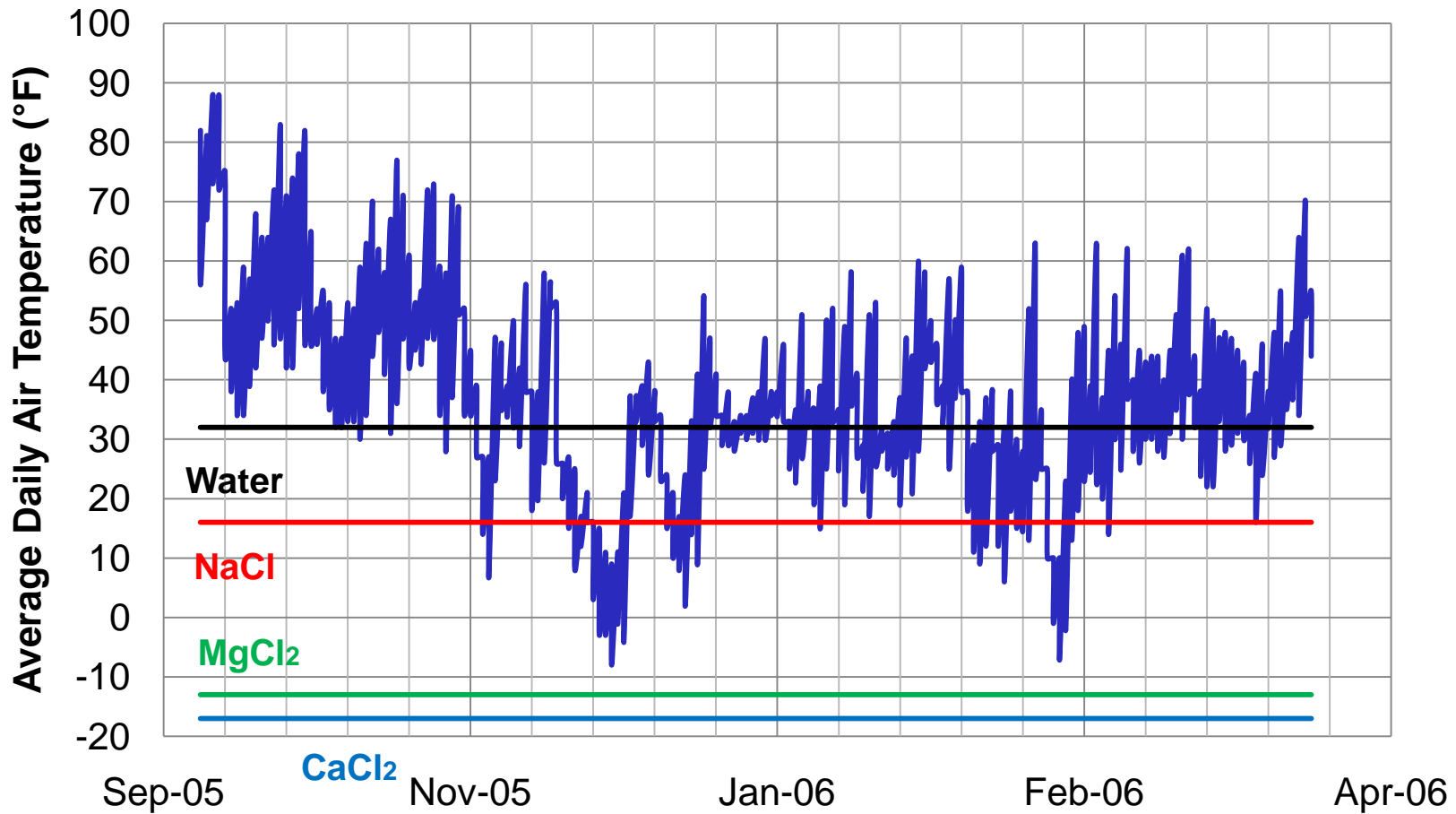

Freeze - thaw cycles

- 2005 through 2010
- November 1st through March 31st

Deicer	Freezing temperature (°F)	Functional temperature (°F)	F/T cycles				
			2005-2006	2006-2007	2007-2008	2008-2009	2009-2010
None	32°F	32°F	80	66	63	69	49
NaCl	-5°F	16 to 20°F	26	27	49	45	40
MgCl ₂ IceStop™	-28°F	0 to -13°F	0	0	0	2	1
CaCl ₂ LiquiDOW™	-60°F	0 to -17°F	0	0	0	2	1



Number of Cycles?

Does salting increase or decrease the number of freeze thaw cycles?

- Cycles may not increase but saturation time likely increases
- Next stage – measure water retention w.r.t. temperature and concentration
- Collect field data

Construction traffic loading

- Could early loading be adding to the problem?

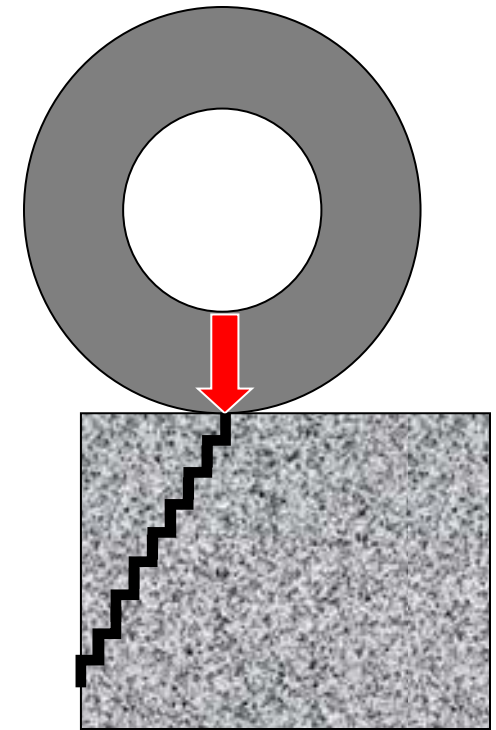
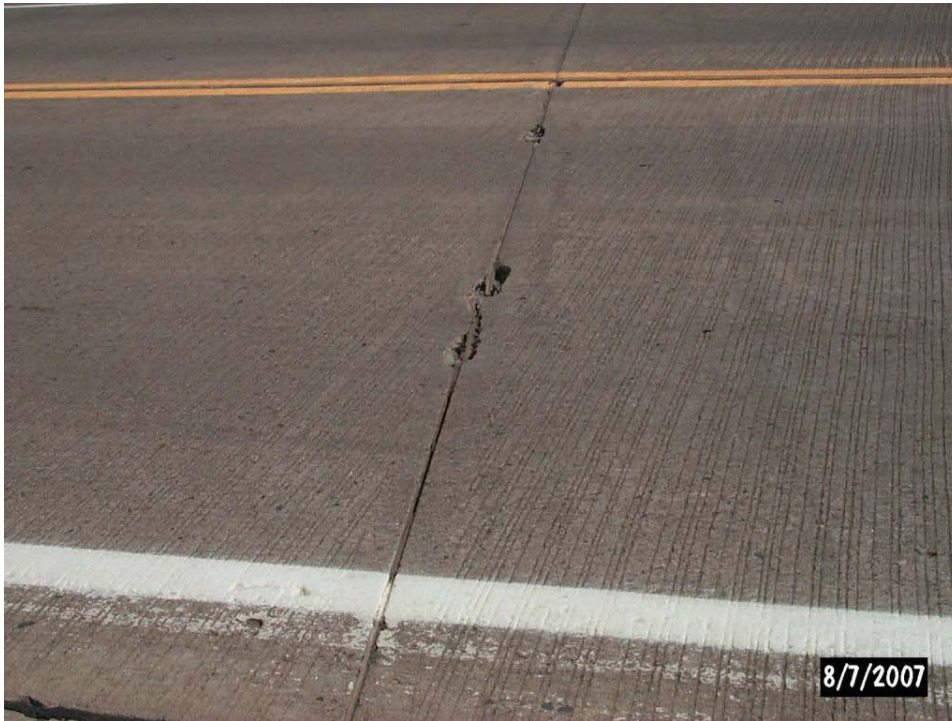

Construction traffic loading

- Construction vehicle ~ Dump truck
(FHWA Class 8 truck)
- Front axle capacity ~ 22 kips
- Rear tandem axle capacity ~ 70 kips



Construction traffic loading

- Tires:
 - ✓ Type ~ 11 R24.5
 - ✓ Number of tires ~ 10 + 2 (lift axle)
 - ✓ Inflation pressure ~ 100 psi
- Load carried by one tire ~ 7.7 kips to 9.2 kips
- Tire / pavement contact area ~ 9 in x 10 in



Construction traffic loading

- Figure shows schematic drawing of tire / pavement load transfer profile

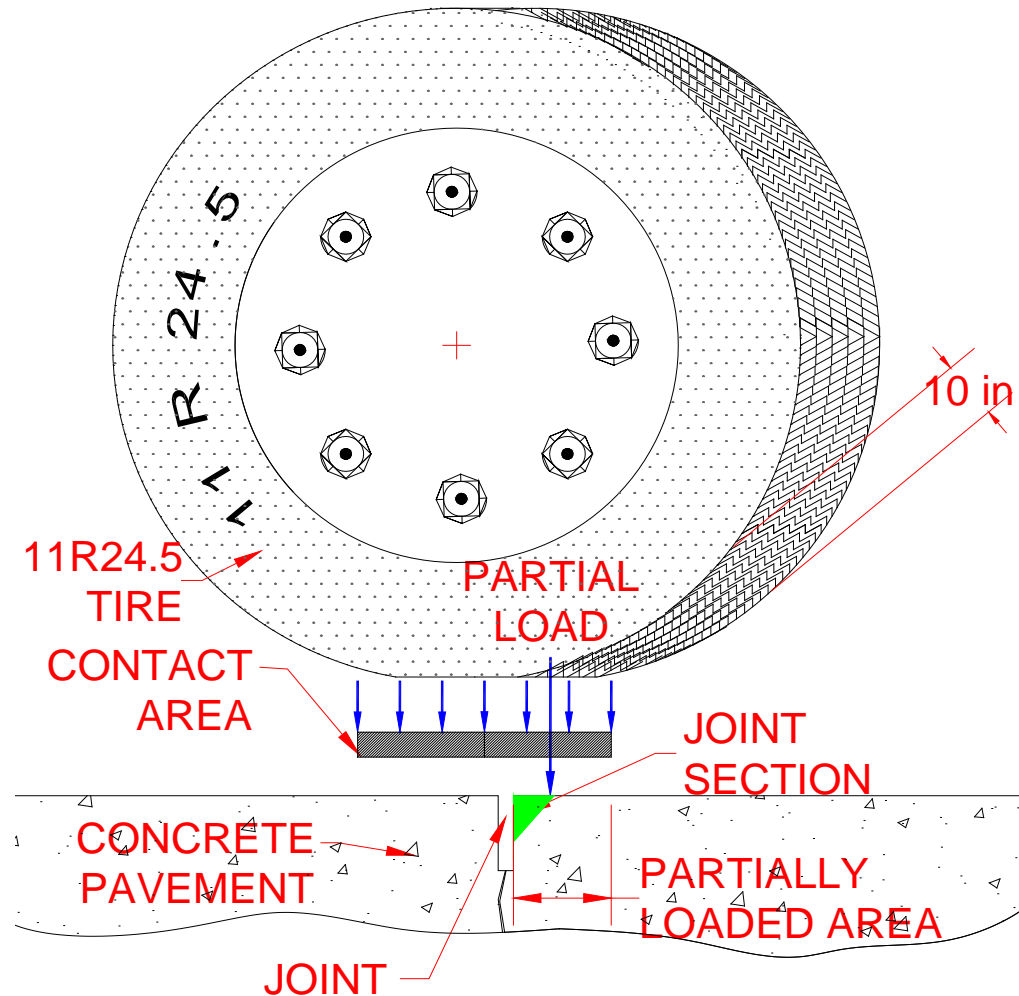

Construction traffic loading

- Figure shows schematic drawing of joint profile
- Size of sawn joint assumed at $\frac{1}{4}$ in width and 4 in depth

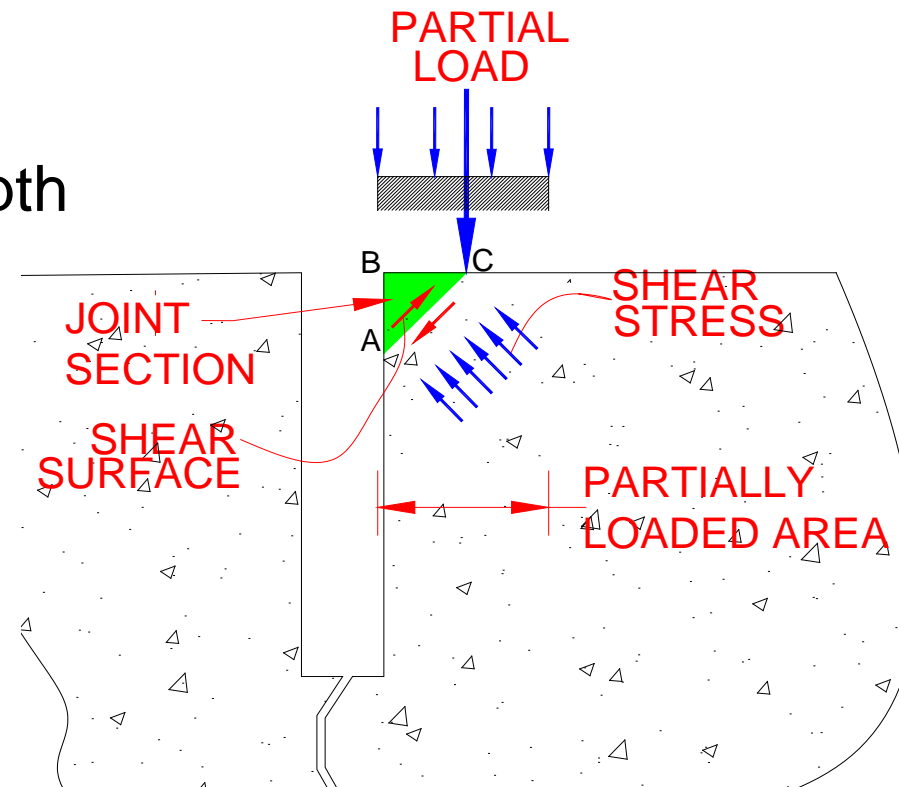

Construction traffic loading

- Table shows the calculated shear stress on joint section loaded at center and 1 in and 2 in off center
- Need 250 psi flexural before construction traffic

	Load position away from the joint (in)				
	0 (in center)	1 in left	2 in left	1 in right	2 in right
Partial load on joint section (lb)	4,400	2,200	6,200	5,200	6,200
Partial area loaded (in x in)	4.4 x 10.0	3.2 x 10.0	2.2 x 10.0	5.2 x 10.0	6.2 x 10.0
Load on the shear plane (lb)	6,200	4,500	3,100	7,400	8,800
Shear stress (psi)	200	200	200	200	200

Freeze Thaw Testing (Round 1)

- Matrix
 - 0 or 15% fly ash
 - Vinsol or “synthetic” AEA
 - Wet cure or curing compound
 - Test in water or 4% NaCl
- Standard IADOT mix
- $w/cm = 0.45$
- Air content $\sim 7\%$
- Standard ASTM C 666 curing and testing



1. 1. 1997

Freeze Thaw Testing

- Total of 32 beams were prepared in pairs
- Three surfaces evaluated:
 - Top (finished)
 - Sides (cast)
 - Sawed face (sawed after 24 hours)



Freeze Thaw Testing

- Freeze-thaw through 300 cycles
- Visual Inspection (ASTM C672)
- Dynamic modulus of elasticity testing (ASTM C 215)



Freeze Thaw Testing

RDM Results

FA	AEA	Cure	Sol'n	RDM, %		
Cycles				240	270	300
0	Syn	CC	H2O	102	103	103
0	Syn	CC	Salt	104	102	101
0	Syn	Wet	H2O	102	101	101
0	Syn	Wet	Salt	99	96	96
0	Vin	CC	H2O	104	104	104
0	Vin	CC	Salt	101	100	100
0	Vin	Wet	H2O	99	95	94
0	Vin	Wet	Salt	0	0	0
15	Syn	CC	H2O	104	104	105
15	Syn	CC	Salt	103	102	100
15	Syn	Wet	H2O	101	100	100
15	Syn	Wet	Salt	95	0	0
15	Vin	CC	H2O	103	103	103
15	Vin	CC	Salt	101	101	100
15	Vin	Wet	H2O	102	101	101
15	Vin	Wet	Salt	93	0	0



Freeze Thaw Testing

Visual ratings

FA	AEA	Cure	Sol'n	Visual Rating, 300 cycles		
				Finished	Formed	Sawed
				Cycles		
0	Syn	CC	H2O	1	3	1
0	Syn	CC	Salt	3	3	1
0	Syn	Wet	H2O	1	1	1
0	Syn	Wet	Salt	4	4	3
0	Vin	CC	H2O	0	3	1
0	Vin	CC	Salt	2	4	1
0	Vin	Wet	H2O	1	3	1
0	Vin	Wet	Salt	5	5	5
15	Syn	CC	H2O	1	3	0
15	Syn	CC	Salt	2	4	1
15	Syn	Wet	H2O	1	2	1
15	Syn	Wet	Salt	5	5	5
15	Vin	CC	H2O	1	3	1
15	Vin	CC	Salt	3	4	3
15	Vin	Wet	H2O	0	1	1
15	Vin	Wet	Salt	5	5	5

Freeze Thaw Testing

0 FA
Syn
Wet cured
Water



Freeze Thaw Testing

15 FA
Syn
Wet cured
Salt



Freeze Thaw Testing

- Most damage in water cured samples tested in salt
- Little difference seen due to AEA type or FA dose
- Air content was high

Freeze Thaw Testing

- Where next?
 - Lower air content
 - Different salts and concentrations
 - Vary SCM type/dose
 - Allow drying in the cycle
 - Ground surfaces
 - Sealants
 - Alternative sawing
 - Cracked specimens
 - Others...?

Field Interviews

- Please send pictures
- Interview questions being developed
- Plan to develop a spreadsheet / database to see trends
- Follow up selected sites with coring and laboratory analysis



Discussion...

